

INSTALLATION INSTRUCTIONS

J.C.B. 212 SU BACKHOE LOADER

HAMMOND AIR CONDITIONING LTD
INGERSOLL, ONT.
1-800-267-2665
1-888-267-3745 (FAX)

JCB 212 SU BACKHOE LOADER INSTRUCTIONS

EVAPORATOR COIL:

The evaporator coil goes inside the heater/blower box alongside the existing heater assembly in the console to the right of the operator.

1. Remove the exterior panel on the right side of the cab and then also remove the interior panel to gain access to the heater/blower assembly.
2. Remove the heater coil from the assembly. (This is not strictly necessary but it does make the installation of the evaporator coil easier). Depending upon the design of the heater coil, it may be necessary to trim or modify the flanges in order to install the evaporator coil.
3. Insert the evaporator coil alongside the heater coil and secure in position. Fill any gaps with the foam supplied in the kit.
4. Insert the thermostat probe into the evaporator coil. The probe should be located at the expansion valve end of the coil approximately 2" from the end and 3" from the bottom of the coil.
5. Leave the access covers off until the system has been tested.



Outer access panel to heater compartment.



Inner access panel to heater assembly.



Evaporator in place beneath heater coil and blowers.

COMPRESSOR:

The compressor is mounted on the engine in the location on the top left of the engine.

1. Open the engine area and access the radiator fan and engine mount area.
2. Remove the fan assembly. Install the add-on pulley supplied in the kit. Note that the pulley may appear reversed from 'normal' configuration when installed.
3. Set the compressor mount in place on the engine and secure with the hardware provided. Use spacers as needed at the front of the mount.
4. Mount the compressor on the compressor mount and secure with the hardware provided. Ensure that the oil fill port is oriented 'UP'.
5. Install the V-belt over the pulley added onto the fan hub and over the front groove on the compressor. Adjust to the desired tension and secure with the compressor mounting hardware.

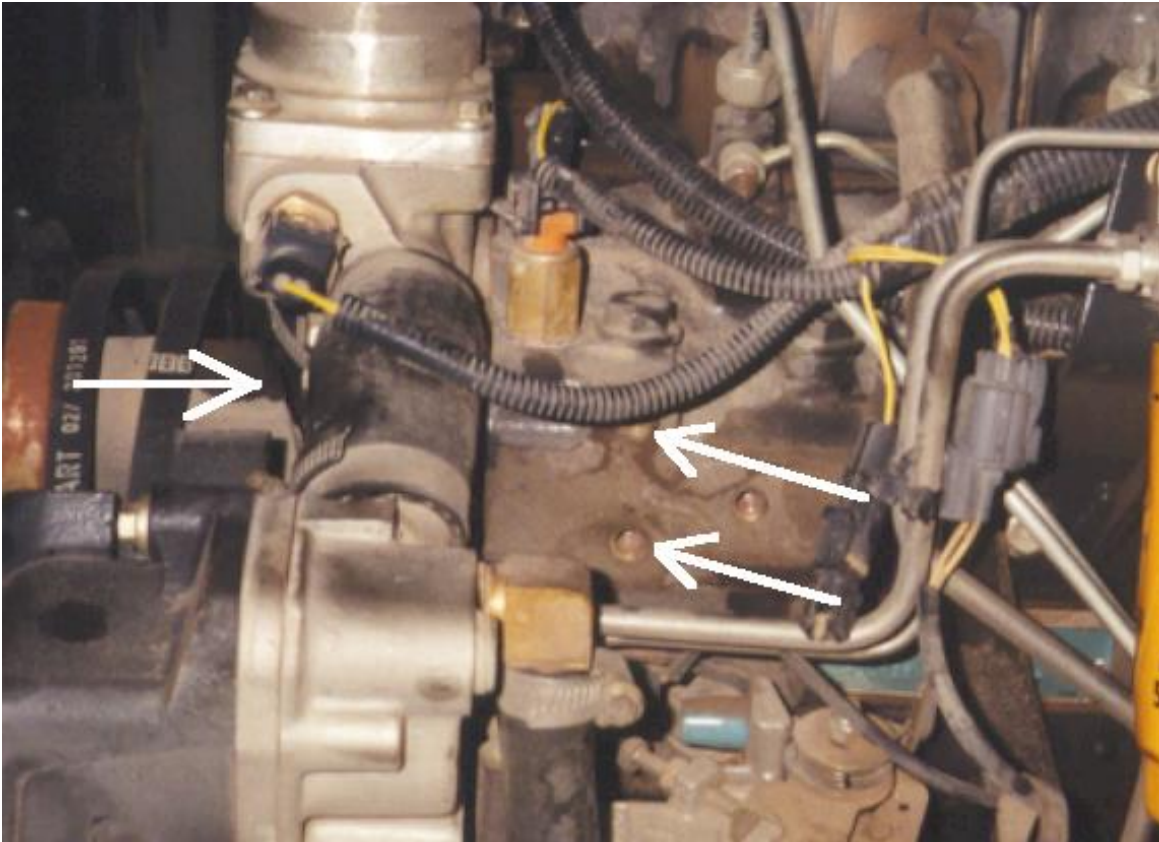

Compressor mounting location on engine. Bolt holes (3) indicated.

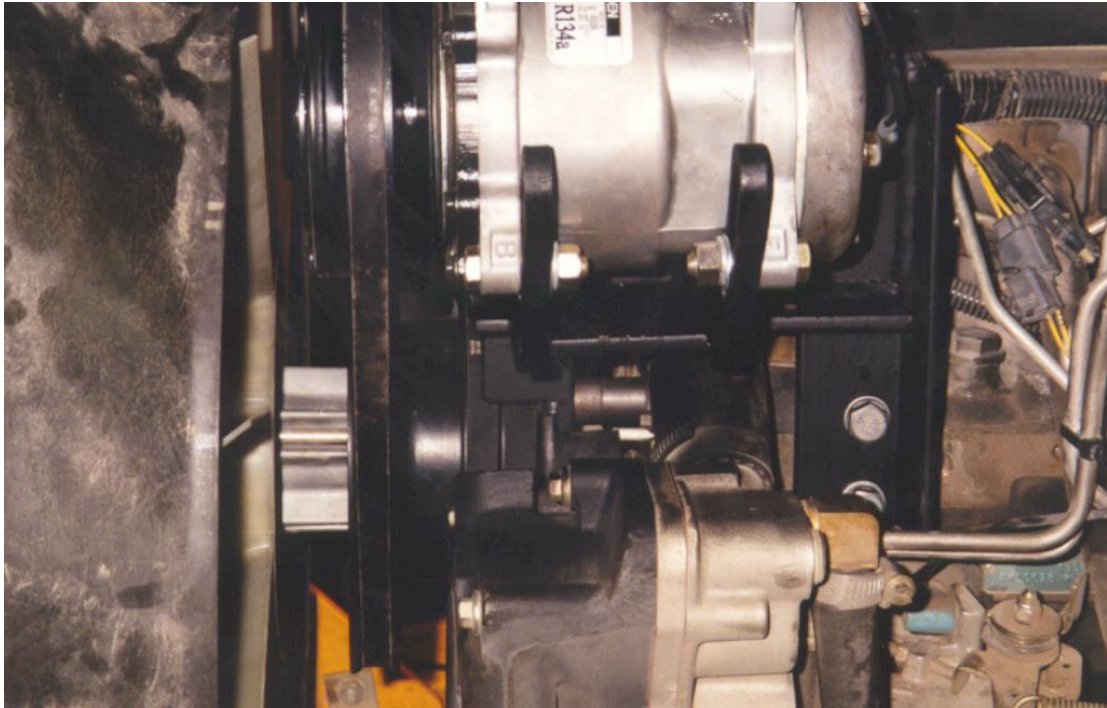

Compressor and mount bracket in place on engine. Note orientation of add-on pulley between fan spacer and factory fan hub pulley.

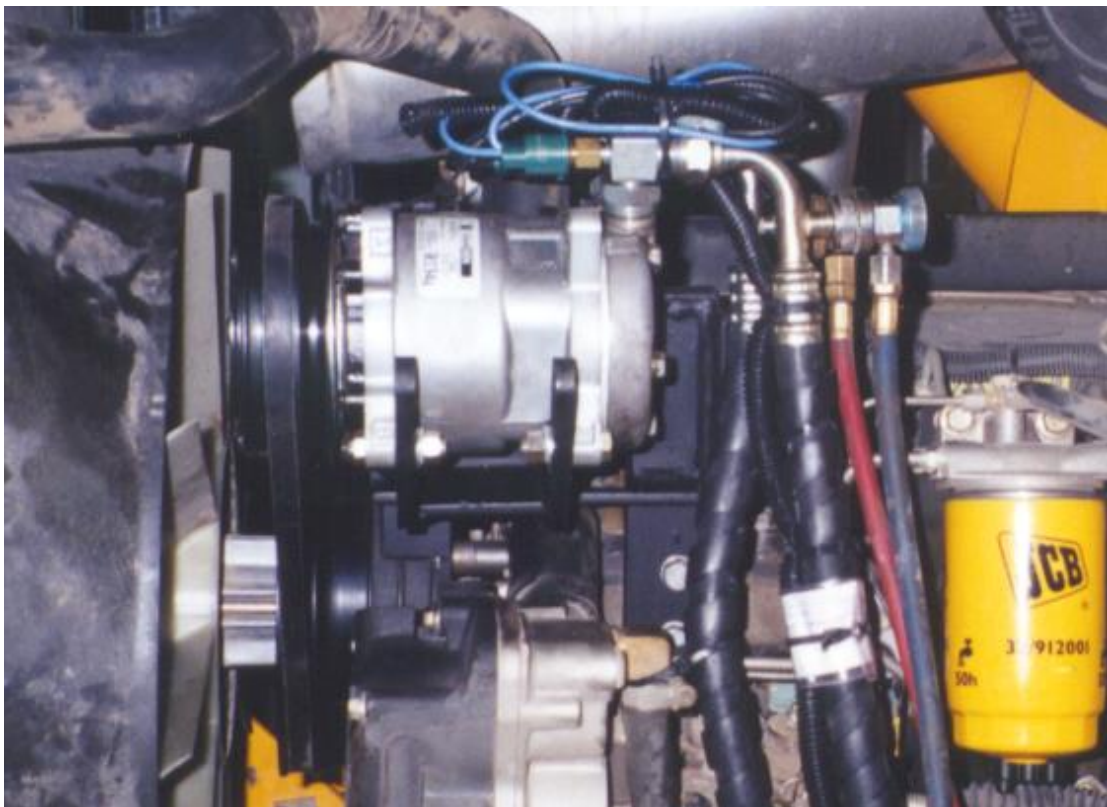

Mount and drive in place with hoses on compressor.

CONDENSER:

The condenser mounts across the face of the radiator.

1. Remove the front grill from the hood of the machine.
2. Set the condenser assembly into position in front of the radiator. Secure to the flanges around the radiator with the self-drilling screws provided in the kit.
3. **NOTE:** It will be necessary to remove the horn assembly to install the condenser. Remount in another location as close as possible to its original location.

DRIER:

The receiver drier is mounted on a straight drier bracket on the side frame of the radiator on an existing bolt.

1. Locate the bolt point to be used to mount the drier bracket. (see picture for location)
2. Mount the drier bracket, install with supplied hardware and tighten.
3. Mount drier to bracket using the two #48 gear clamps provided. Ensure the 'INLET' fitting of the drier is oriented toward the front of the machine.



Drier in place on right side frame member. Nut showing is for mounting bracket.

HOSE RUNS:

The hoses are all pre-crimped and pressure tested for leaks.

13/32" Hose Compressor to Condenser:

The hose runs from the rotolock on the compressor fitting (the 90o at the end of the hose with the 134a access tee in place) to the top fitting on the condenser. The hose is routed down along the side of the engine and then forward along the side of the radiator. The hoses run behind the condenser with the 13/32" 90o fitting connecting to the top fitting. See the pictures for the condenser installation above.

5/16" Hose Condenser to Drier:

The hose runs from the condenser outlet fitting (bottom) to the drier along with the 13/32" line from the compressor. Connect one 90o fitting to the condenser and loop the hose behind the condenser and back beside the radiator and out along the frame on the left side of the machine. Connect the other 90o fitting to the 'INLET' fitting on the drier.

5/16" Hose Drier to Evaporator:

The hose runs from the drier along the side of the frame and up into the cab on the right side of the operator. The hose is run into the cab with the 1/2" suction line from the compressor. Run both the lines up into the cab through the existing grommet near where the evaporator fittings are exposed. The grommet may need to be slit to allow the hoses through. Cut off the extra hose and crimp the appropriate fitting onto the hose to connect to the inlet fitting of the expansion valve.

1/2" Hose Evaporator to Compressor:

The 1/2" hose is first connected at the compressor using the 90o fitting with the access port for charging crimped next to it. Connect this fitting to the compressor fitting and run the hose back as shown. The hose will cross over to the right side of the machine under the cab and behind the engine with the 5/16" hose. It then follows the 5/16" hose into the cab and up to the evaporator. Cut the hose to length and crimp on the appropriate fitting to connect to the suction side of the evaporator.

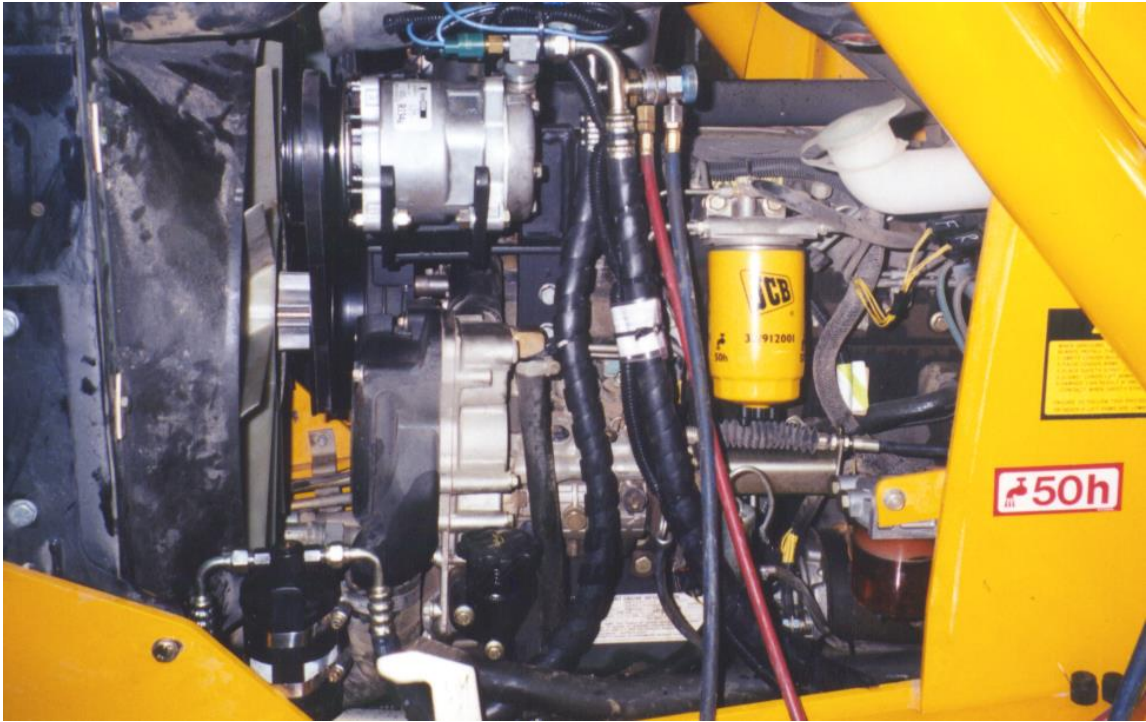

Hose routing at compressor and off of drier.

ELECTRICAL:

There are two electrical configurations available for the air conditioning system for the JCB backhoe loaders. One utilizes the factory ON-OFF rocker switch for the air conditioning. The other uses a thermostat mounted on the dash panel to both control the ON-OFF function of the air conditioning and control the clutch cycling for temperature control.

1. The first requires the installation of the factory rocker switch with the 'snowflake' emblem on it. Supply ignition live power to the switch and determine the 'output' terminal. The best power supply is from the blower switch. Determine which lead from the blower switch is live when the blower is functioning at any speed and use this lead to supply power to the A/C ON-OFF switch. From the output terminal run a 14ga black wire down to the thermostat. The thermostat in this case will either be a pre-set mounted down by the evaporator case or controllable thermostat mounted out of the way but still accessible to adjust if necessary. From the other side of the thermostat run the 14ga black clutch wire out of the cab with the refrigerant hoses and up to the compressor. Connect to the pressure switches in series and then to the compressor clutch.
2. For the second option use the same power lead from the blower control switch and connect to the rotary thermostat mounted in the control panel as shown in the picture below. The clutch wire runs from the thermostat out to the pressure switches and compressor clutch as above.



Thermostat location on dash panel.

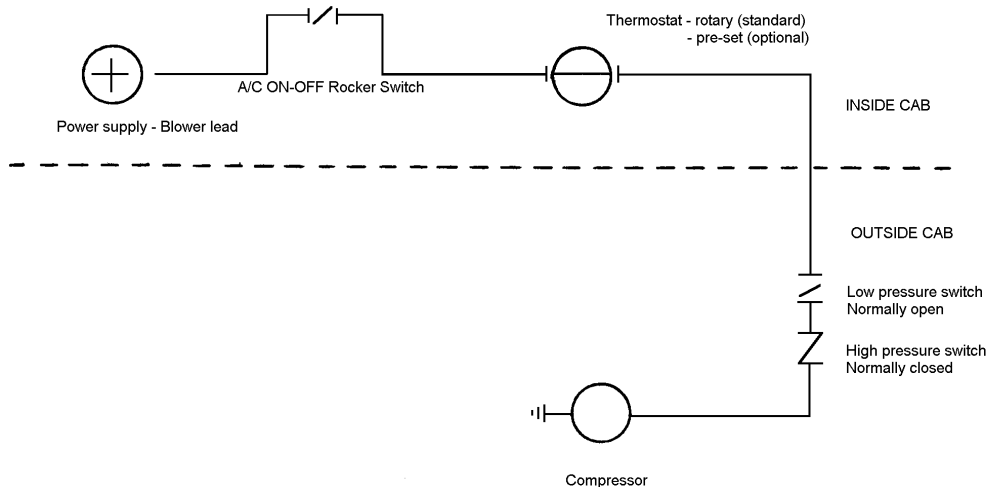

Wiring for option 1.

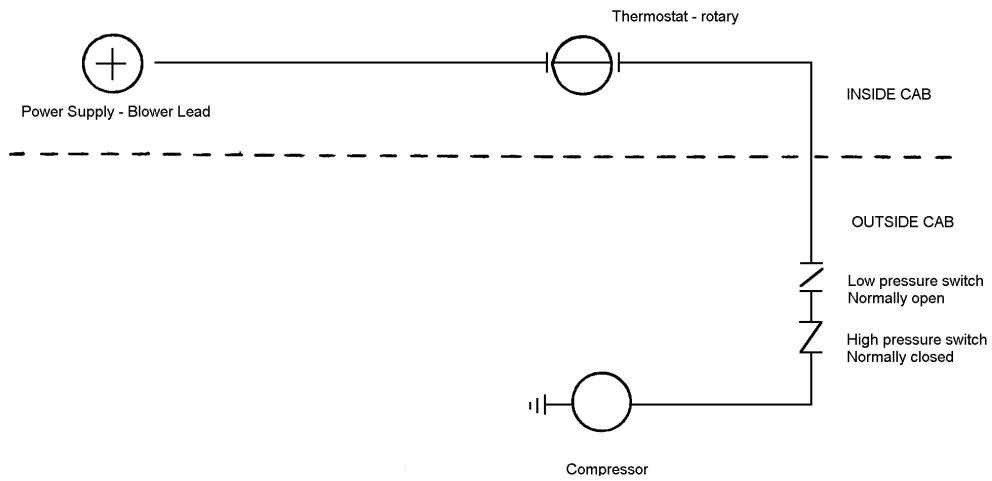

Wiring for option 2.

CHARGING AND TESTING

- 1) Pressure test the system using nitrogen to a pressure of 250 psi. Check for leaks.
- 2) Add 2oz of SP20 Sanden PAG oil to the system.
- 3) Vacuum the system for at least ½ hour.
- 4) Check that the vacuum holds.
- 5) Fill the system with 2.5 of R134a refrigerant. **DO NOT USE ANY OTHER TYPE OF REFRIGERANT OR IT WILL VOID THE WARRANTY.**
- 6) Test the system. Check the cycling temperature of the thermostat. Adjust the thermostat settings if required to avoid coil freeze up problems. See the thermostat setting procedures at the end of these instructions.

Refrigerant Flow Pattern in a Standard Air Conditioning System

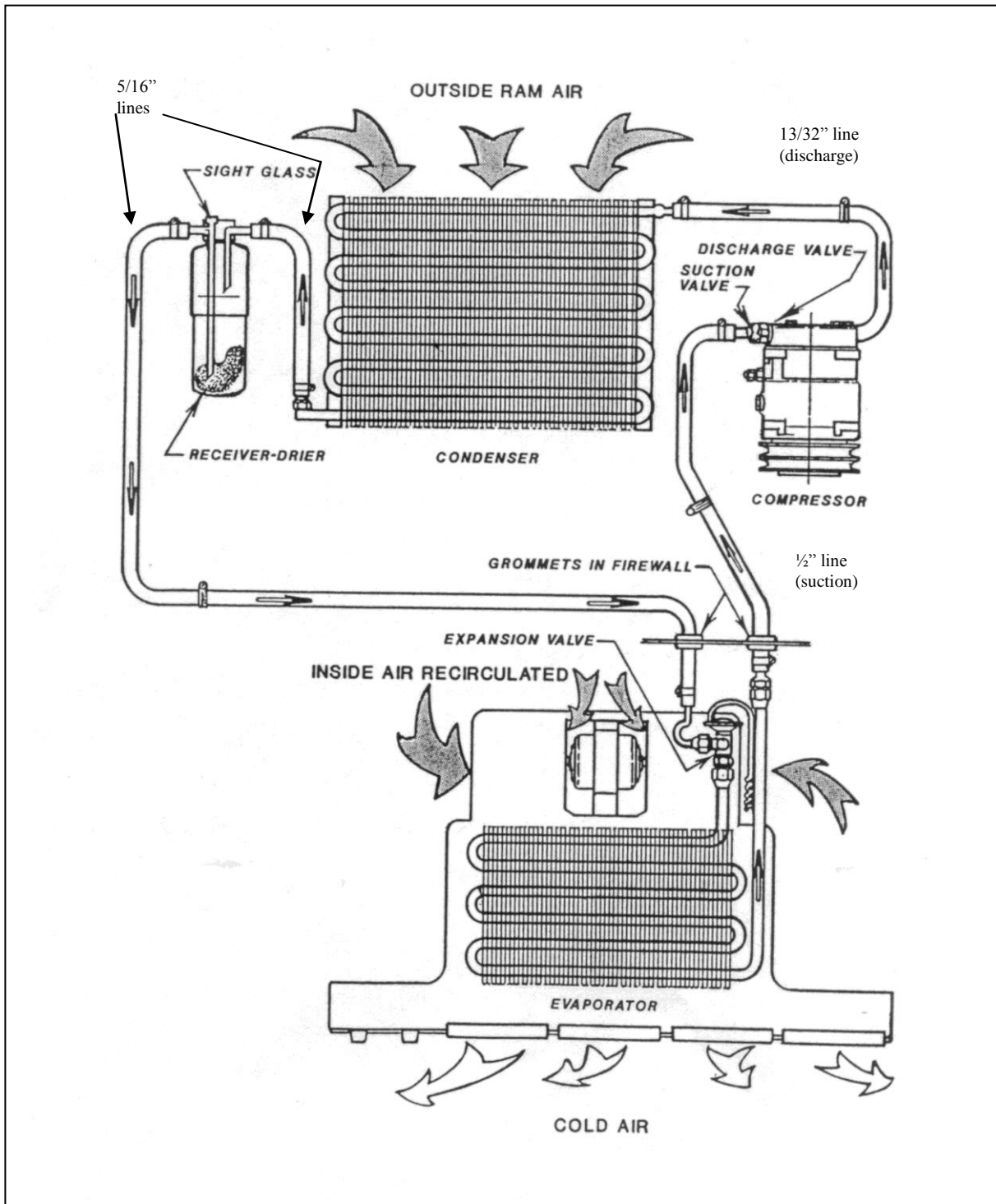

Thermostat Setting Procedures

- 1) Thermostat types
 - a) preset
 - b) adjustable
 - a) A preset thermostat is adjusted to its specific cut in and cut out temperatures when manufactured and does not have a rotary adjustment for the operator.
 - b) An adjustable or rotary thermostat has been manufactured to a predetermined cut in and cut out temperatures, but it is also operator adjustable to achieve the desired comfort level.

Both types of thermostats can have their factory settings adjusted by turning the setting screws on the body of the thermostat. One body type has the setting screws mounted externally and labeled for direction of rotation. The other body type requires the removal of the plastic end plate to expose the set screw.

- 2) Thermostat probe location: The location of the thermostat probe in an evaporator coil can be very important to achieve the maximum cooling potential of the coil while also preventing coil freeze-up. There is no set location for the thermostat probe to be put that will be optimum for all systems, but several rules of thumb may be followed:
 - a) Insert the probe in the coldest area of the evaporator coil.
 - b) Insert the probe from the top of the coil down, if possible.
 - c) Make sure that at least the last 3" of the thermostat probe are in the coil.

To find the most likely area where the coil is the coldest, consider these factors:

- 1) Direction of air flow through the coil.
 - 2) The coil area likely to have the lowest air flow.
 - 3) The inlet locations of the refrigerant into the coil.
 - 4) The inlet of the hotter outside air into the coil area.
-
- 1) Usually the coldest side of the evaporator coil will be the air outlet side. Often the thermostat probe can be inserted between the last and second last row of tubes.
 - 2) The lower air flow area of the evaporator coil in most systems tends to be near either end of the coil. These areas will be colder
 - 3) The area of the coil that the refrigerant inlet tube(s) occupy should be the coldest part of the coil.
 - 4) If the system is equipped with an outside air intake, where and how that air is brought into the evaporator area can have a large effect on the coil temperature. If all the outside air is piped into the evaporator in one area, that area will be considerably warmer in hot weather.

By looking at all these different factors, the area of an evaporator coil most likely to be the coldest can be determined.

Once the probe is inserted, the A/C system needs to be tested. Run the system to ensure that the thermostat is cycling the compressor off at the appropriate temperature. A core temperature ranging between 25° and 30° F should cause the thermostat to cycle off. The air temperature at the vent outlet closest to the evaporator coil should be between 38° F and 45° F when the compressor cycles off.

If the thermostat doesn't cycle off after a reasonable cool down period, and the air outlet temperature has dropped below 40° F, the cut in and cut out settings should be adjusted until the compressor is cycling on and off regularly. Let the system run for a decent time period (at least 15 min) and then check the evaporator coil for any signs of freezing.

Aeroquip E-Z Clip Assembly Instructions

Step 1. Cut the hose to proper length with an appropriate cutting tool. Aeroquip's hand held hose cutter has been specially designed for cutting all non-wire reinforced hose, such as GH-134 Multi-Refrigerant hose. Be sure the cut is made square to the hose length.

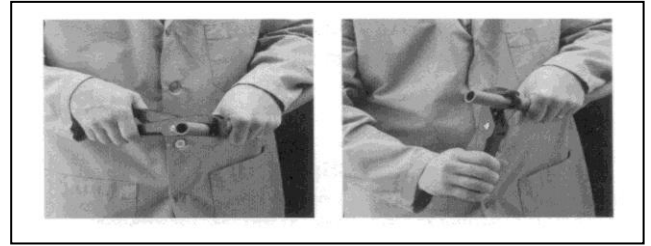

Step 2. Install two proper-sized clips onto the cut end of the hose. Orientation of the clips does not affect the performance of the connection. However, for ease of assembly, both clips should have the same orientation. NOTE: Failure to slide the clips over the hose at this time will require the clips to be stretched over the hose or fitting later. This may permanently damage the clip.

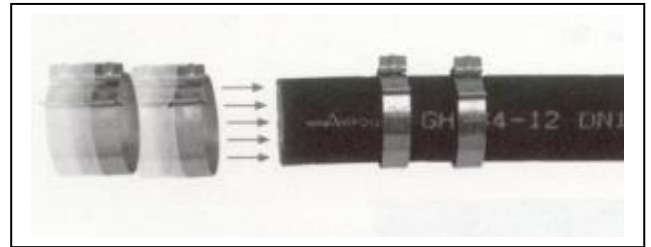

Step 3. Lubricate the nipple with a generous amount of the refrigeration or A/C system's compressor lubricating oil. This MUST be done to lower the force of nipple insertion.

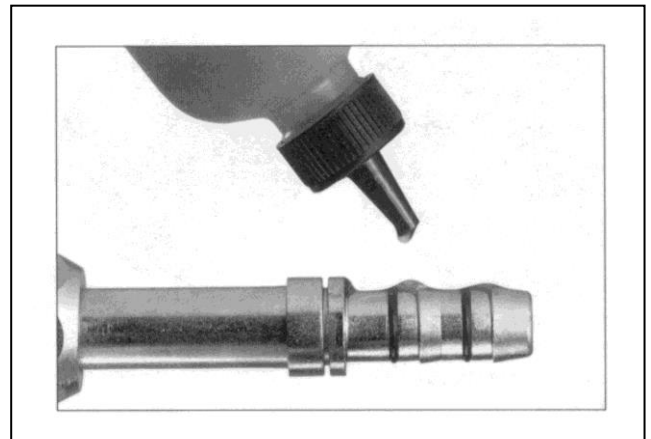

Step 4. Insert the nipple into the hose. To ensure that the nipple is fully inserted, check the gap between the cut end of the hose and the shoulder on the nipple. Care should be taken to avoid kinking or other damage to the hose during nipple insertion.

NOTE: Be sure to wipe excess oil from the nipple and hose.

Step 5. Snap the cage into the groove on the nipple. The arms should extend over the hose length. When the cage has been correctly installed in the cage groove, the cage will be able to rotate in the groove. This step MUST be performed to ensure:

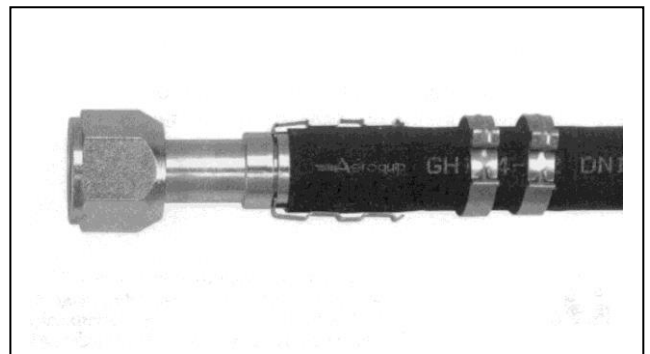

1. The clips will be located over the O-rings on the nipple.
2. The connection will be compatible with the connection's pressure rating.

Step 6. Slide the clips over the cage arms and into the channels on each arm.



Step 7. Use the pliers to close the clips. The pliers should be positioned squarely on the clip connection points and should remain square during the closing of the clip.

NOTICE: E-Z Clip components should not be reused.

